

# 铅酸电池充电器

Lead-acid battery charger

用户手册



## 安全注意事项 Safety Precautions

在开始操作之前,请仔细阅读操作指示、注意事项,以减少意外的发生。产品及产品手册中的“小心、注意、警告、危险”事项,并不代表所应遵守的所有安全事项,只作为各种操作安全注意事项的补充。因此,负责该系列产品安装、操作的人员必须掌握系统正确的操作方法及各种安全注意事项后方可进行设备的各项操作。

在进行本公司产品、设备的各项操作时,必须遵守相关行业的安全规范,严格遵守由我们公司提供的相关设备注意事项和特殊安全指示。

Please read the operating instructions and precautions carefully before starting operation to reduce accidents. The "Caution, Note, Warning, Danger" items in the product and product manual do not represent all safety precautions to be observed, but only serve as supplements to various operational safety precautions. Therefore, personnel responsible for the installation and operation of this series of products must master the correct operating methods of the system and various safety precautions before performing various equipment operations.

When performing various operations on the products and equipment of our company, relevant industry safety specifications must be followed, as well as the relevant equipment precautions and special safety instructions provided by our Company.

## 电气安全 Electrical Safety

### 高压 High Voltage



危险  
Danger

本电源系统运行时部分部件带有高压,直接接触或通过潮湿物体间接接触这些部件,会带来致命的危险。

Some components of this power supply system carry high voltage during operation. Direct contact or indirect contact with these components through wet objects may cause fatal danger.

交流电源设备的安装,必须遵守相关行业的安全规范,进行交流设备安装的人员,必须具有高压、交流电等作业资格。

操作时严禁在手腕上佩戴手表、手链、手镯、戒指等易导电物体。

发现机柜有水或潮湿时,请立刻关闭电源。在潮湿的环境下操作时,应严格防止水分进入设备。

安装过程中不能容许操作的开关和按钮上,必须挂上禁止标识牌。

Wearing conductive objects such as watches, bracelets, bangles and rings on the wrist is strictly prohibited during operation.

Turn off the power immediately if water or moisture is found in the cabinet. Strictly prevent water from entering the equipment when operating in a humid environment.

Prohibition signs must be hung on switches and buttons that are not allowed to be operated during installation.



**危险**  
Danger

高压线路的施工操作，可能导致起火或电击意外。交流电缆的架接、走线经过区域必须遵循所在地的法规和标准。只有具有高压、交流电作业资格的人员才能进行各项高压操作。

Construction and operation of high-voltage lines may lead to fire or electric shock accidents. The routing and installation area of AC cables must comply with local laws and specifications. Only personnel with qualifications for high-voltage and AC electrical operations are allowed to perform various high-voltage operations.

## 工具 Tools



**警告**  
Warning

在作业过程中必须使用专用的防护用具，如防护服、绝缘鞋，戴护目镜、安全帽、绝缘手套等。

Special protective equipment such as protective clothing, insulated shoes, goggles, safety helmets and insulated gloves must be used during operation.

## 雷雨 Thunderstorms



**危险**  
Danger

严禁在雷雨天气下进行高压、交流电，及铁塔、桅杆作业。

High-voltage, AC electrical operations, as well as operations on iron towers and masts are strictly prohibited in thunderstorm weather.

在雷雨天气下，大气中会产生强电磁场。因此，为避免雷击损坏设备，要及时做好设备的良好接地。

Strong electromagnetic fields are generated in the atmosphere during thunderstorm weather. Therefore, to avoid equipment damage caused by lightning strikes, ensure good grounding of the equipment in a timely manner.

## 静电 Static Electricity



**警告**  
Warning

人体产生的静电会损坏电路板上的静电敏感元器件，如大规模集成电路 (IC) 等。在接触设备，手拿插板、电路板、IC 芯片等前，为防止人体静电损坏敏感元器件，必须佩戴防静电手腕，并将防静电手腕的另一端良好接地。

Static electricity generated by the human body may damage electrostatic sensitive components on circuit boards, such as large-scale integrated circuits (ICs). Before touching the equipment, holding plug-in boards, circuit boards, IC chips, etc., to prevent damage to sensitive components by human static electricity, an anti-static wrist strap must be worn and the other end of the anti-static wrist strap must be properly grounded.

## 短路 Short Circuit



**危险**  
Danger

严禁操作时将电源系统直流配电正负极短路或将非接地极对地短路。电源设备为恒压直流供电设备，短路将会引起设备烧毁和人身安全危害。

Short-circuiting the positive and negative poles of the DC power distribution of the power supply system or short-circuiting the non-grounded pole to the ground during operation is strictly prohibited. The power supply equipment is a constant-voltage DC power supply device, and short-circuiting may cause equipment burnout and personal safety hazards.

在进行带电作业时必须严格检查线缆和接口端子的极性。  
系统配电操作空间紧凑,任何操作之前要注意选好操作空间。  
操作时严禁在手腕上佩戴手表、手链、手镯、戒指等易导电物体。  
操作必须使用绝缘工具。

Strictly check the polarity of cables and interface terminals during live-line work.  
The operating space for system power distribution is compact; select a proper operating space before any operation.  
Wearing conductive objects such as watches, bracelets, bangles and rings on the wrist is strictly prohibited during operation.  
Insulated tools must be used for all operations.

## 电池 Battery

 <p><b>危险</b> Danger</p>	<p>进行电池作业之前,必须仔细阅读电池搬运的安全注意事项,以及电池的准确连接方法。 Before performing battery operations, the safety precautions for battery handling and the correct battery connection method must be carefully read.</p>
---	--

电池的不规范操作会造成危险。操作中必须严格注意、小心防范电池短路或电解液溢出、流失。电解液的溢出会对设备构成潜在性的威胁,会腐蚀金属物体及电路板,造成设备损坏及电路板短路。

电池安装、操作前,为确保安全,应注意如下事项:

摘下手腕上的手表、手链、手镯、戒指等含有金属的物体。使用专用绝缘工具。

使用眼睛保护装置,并做好预防措施。

使用橡胶手套,佩戴好预防电解液溢出的围裙。

电池在搬运过程中应始终保持电极正面向上,严禁倒置、倾斜。

Improper battery operation may cause danger. Strict attention and precautions must be taken to prevent battery short-circuit or electrolyte spillage and loss during operation. Electrolyte spillage poses a potential threat to the equipment, corroding metal objects and circuit boards, resulting in equipment damage and circuit board short-circuit.

To ensure safety before battery installation and operation, the following points should be noted:

Remove metal objects such as watches, bracelets, bangles and rings from the wrist. Use special insulated tools.

Use eye protection devices and take preventive measures.

Wear rubber gloves and an apron to prevent electrolyte spillage.

Batteries must be kept with electrodes facing up during handling; inversion and tilting are strictly prohibited.

## 其他

### Other Precautions

## 安装要求 Installation Requirements

 <p><b>警告</b> Warning</p>	<p>在更换系统空开及输出接触器时,必须采用同规格的器件,以符合安规要求。 When replacing the system air switch and output contactor, devices of the same specification must be used to comply with safety regulation requirements.</p>
--	--

## 物体尖角 Sharp Object Edges

 <p><b>警告</b> Warning</p>	<p>用手搬运设备时,要佩戴保护手套,防止利物割伤。 Wear protective gloves when handling the equipment by hand to prevent cuts from sharp objects.</p>
--	---

 <p><b>注意</b> Note</p>	<p>在连接电缆之前,确认电缆及电缆标签与实际安装是否相符。 Before connecting cables, confirm that the cables and cable labels match the actual installation.</p>
---	--

# 目录

## Table of Contents

一、产品概括 .....	2
1.Product Overview	
二、工作原理概述 .....	3
2.Working Principle Overview	
三、安装说明 .....	4
3.Installation Instructions	
四、面板、触摸屏说明 .....	6
4.Panel and Touch Screen Description	
五、使用方法 .....	9
5.Operation Method	
六、保护和故障列表 .....	11
6.Protection and Fault List	
七、维护与保养 .....	13
7.Maintenance and Upkeep	
八、包装、运输及储存 .....	14
8.Packaging, Transportation and Storag	
附录A: 充电机接线原理图 .....	15
Appendix A: Charger Wiring Schematic	
附录B: 常见故障及处理 .....	16
Appendix B: Common Faults and Troubleshooting	
附录C: 故障处理流程图 .....	17
Appendix C: Fault Handling Flow Chart	
附录D: 常用检修工具 .....	19
Appendix D: Common Maintenance Tools	
	20
	21

---

# 一、产品概括

## 1. Product Overview

本系列充电机采用全球领先的 LLC 谐振模式和 DSP 数字控制, 专门为锂电池充电功率变换设备而设计。具有宽输入/输出电压范围、高功率密度、高可靠性、智能化控制和造型美观等特点。充电机采用风冷的散热方式, 功率密度高, 占用空间小。触摸屏显示, 能直观的了解实时充电状态及故障信息。

This series of chargers adopts the world's leading LLC resonant mode and DSP digital control, and is specially designed for lithium battery charging power conversion equipment. It features a wide input/output voltage range, high power density, high reliability, intelligent control and an attractive appearance. The charger adopts air cooling for heat dissipation, with high power density and small space occupation. The touch screen display allows for intuitive understanding of real-time charging status and fault information.

## 二、工作原理概述

### 2. Working Principle Overview

充电机由三相高功率电源模块、控制板、触摸屏、辅助电源、输入、输出检测及保护电路组成。电源模块具备有源 PFC 电路和 EMI 输入电路实现交流输入的整流滤波和功率因素的校正, 以满足 EMC 标准和得到小于 5% 的电流总谐波含量; 三相有源 PFC 由单独的 DSP 进行控制, 根据交流输入电压, 对输入电流进行校正, 使其跟随交流输入电压, 并按照环路计算的结果产生 PWM 波进行驱动主电路, 并执行相关的保护措施; 后级的 DC/DC 变换器 LLC 技术, 由 DSP 产生 PWM 波控制 DC/DC 变换的直流电压、经过高频变压器耦合输出后再整流滤波输出电流电压, 从而将前级整流电压转换成充电需求稳定的直流电压。

辅助电源利用三相输入电源隔离变换直流输出, 产生控制电路所需的各路电源。输入/输出检测电路采集电流、电压、温度等参数反馈于控制板, 用于调节电源模块输出参数, 并驱动保护相关执行元器件。

充电机 CAN 总线与电池 BMS 通讯, 实时跟踪调节充电参数, 使充电机始终工作在高效可靠的充电状态, 提高了充电效率和节约电能。

The charger consists of a three-phase high-power power module, a control board, a touch screen, an auxiliary power supply, and input and output detection and protection circuits. The power module is equipped with an active PFC circuit and an EMI input circuit to realize rectification and filtering of AC input and power factor correction, so as to meet EMC standards and achieve a total current harmonic content of less than 5%. The three-phase active PFC is controlled by an independent DSP, which corrects the input current according to the AC input voltage to make it follow the AC input voltage, and generates PWM waves to drive the main circuit according to the results of loop calculation, and implements relevant protection measures. The post-stage DC/DC converter adopts LLC technology, in which the DSP generates PWM waves to control the DC voltage of DC/DC conversion, which is coupled by a high-frequency transformer and then rectified and filtered to output current and voltage, thereby converting the pre-stage rectified voltage into a stable DC voltage required for charging.

The auxiliary power supply uses three-phase input power for isolated conversion to DC output, generating various power supplies required for the control circuit. The input/output detection circuit collects parameters such as current, voltage and temperature and feeds them back to the control board, which is used to adjust the output parameters of the power module and drive protection-related executive components.

The charger's CAN bus communicates with the battery BMS to track and adjust charging parameters in real time, so that the charger always works in an efficient and reliable charging state, improving charging efficiency and saving electric energy.

## 三、安装说明

### 3. Installation Instructions

#### 1、安装注意事项：

##### 1. Installation Precautions

本电源系统内部某些器件的工作电压及电流很大，为保证人身安全，应时刻遵守以下规定：

- 1) 只有接受过电源系统培训并充分掌握电源系统知识的人员才可以安装此电源系统。安装过程中，应始终要遵守前述列出的安全规定及本地安全规定。
- 2) 系统电压可能达 330Vdc 或 475Vac，是危险电压，安装及操作时需要作好绝缘防护，以保障人身安全。
- 3) 如要在电源系统机柜内部操作，应确保电源系统不带电。必须断开电源系统的市电输入及电池电源。
- 4) 将充电设备置于专用区域，由设备的负责人操作设备。

Some devices inside the power supply system operate at high voltage and current. To ensure personal safety, the following regulations must be observed at all times:

1. Only personnel who have received training on the power supply system and fully master the knowledge of the power supply system can install this power supply system. The safety regulations listed above and local safety regulations must be observed throughout the installation process.
2. The system voltage can reach 330Vdc or 475Vac, which is a dangerous voltage. Insulation protection must be provided during installation and operation to ensure personal safety.
3. If it is necessary to operate inside the power supply system cabinet, ensure that the power supply system is de-energized. The mains input and battery power of the power supply system must be disconnected.
4. Place the charging equipment in a dedicated area and operated by the person in charge of the equipment.

#### 2、交流输入接线

##### 2.AC Input Wiring

充电机交流输入采用的是三相四线电缆，线长 3 米，线缆定义如下：

The AC input of the charger adopts a three-phase four-wire cable with a length of 3 meters, and the cable definition is as follows:

相线:棕色、灰色、黑色: 3\*6mm<sup>2</sup>  
Phase Wires: Brown, Gray, Black; 3\*6mm<sup>2</sup>

地线:黄绿双色:1\*4mm<sup>2</sup>  
Ground Wire: Yellow-green dual color; 1\*4mm<sup>2</sup>

请按照对应线色或线号管，把充电机交流输入电缆线与市电 AC380V 相接；

Connect the AC input cable of the charger to the mains AC380V according to the corresponding wire color or wire number tube.



#### 注意 Note:

- 1) 单台充电机安装交流输入每根电缆线径不得低于 6mm<sup>2</sup>；
- 2) 建议每台充电机通过小型断路器连接到市电源上，其中：  
48V100A机型、48V200A机型、80V100A机型      断路器规格 ≥32A  
80V200A机型      断路器规格 ≥63A
- 3) 该型号充电机没有零线；严禁把地线接到零线上；

The wire diameter of each AC input cable for a single charger installation shall not be less than 6mm<sup>2</sup>;  
It is recommended to connect each charger to the mains through a miniature circuit breaker, among which:  
Circuit breaker specification ≥32A for 48V100A, 48V200A and 80V100A models  
Circuit breaker specification ≥63A for 80V200A model  
This model of charger has no neutral wire; connecting the ground wire to the neutral wire is strictly prohibited.

### 3、开机检查：

#### 3. Startup Inspection

充电机接好后,应进行通电开机检查,内容如下:

- 1) 确认输入电源满足充电机需求,交流输入电缆线已正确连接;
- 2) 操作输入电源和充电机断路器或空开在接通位置;

此时充电机电源接通,充电机进入待机界面,请确认充电机屏幕显示正常,无故障提醒;

Confirm that the input power meets the charger's requirements and the AC input cable is correctly connected;

Switch on the input power and the charger's circuit breaker or air switch;

The charger is powered on and enters the standby interface. Confirm that the charger screen displays normally without fault prompts.



**注意** Note:

在开机检查过程如发现异常,请立刻断开充电机输入电源;

If an abnormality is found during the startup inspection, turn off the input power of the charger immediately.

## 四、面板、触摸屏说明

### 4. Panel and Touch Screen Description

#### 1、面板介绍

##### 1. Panel Introduction

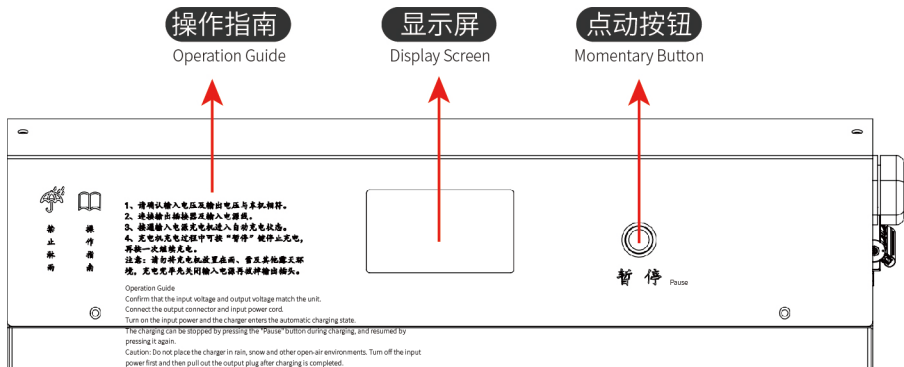

#### 2、触摸屏主界面

##### 2.Touch Screen Main Interface

主界面包含充电电压、电流、时间、功率及电池SOC等信息并显示机器工作状态。点击触摸屏上的SOC区域图标进入电池信息界面。

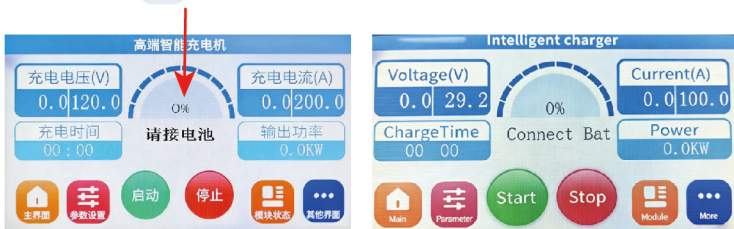

The main interface displays information such as charging voltage, current, time, power and battery SOC, and shows the machine working status. Click the SOC area icon (0%) on the touch screen to enter the battery information interface.

#### 3、电池信息界面

##### 3.Battery Information Interface

电池信息界面包含实时BMS发出的充电需求和报文及电池状态，点击“电池界面”页头进入报文界面。点击“主界面”可返回主界面。

The battery information interface contains the real-time charging demand and messages sent by the BMS as well as the battery status. Click the header of the "Battery Interface" to enter the message interface. Click the "Main Interface" to return to the main interface.



## 4、参数界面

### 4. Parameter Interface

点击“参数设置”进入参数界面包含修改电流、电压等必要参数。点击“主界面”可返回主界面。

**(注意:非专业人员请勿随意修改出厂参数)**

Click "Parameter Setting" to enter the parameter interface, which includes the necessary parameters for modifying current, voltage, etc. Click the "Main Interface" to return to the main interface.

**(Note: Non-professionals are not allowed to modify the factory parameters at will.)**



## 5、其他界面

### 5. Other Interfaces

点击“其他界面”进入机器软件版本界面。本页显示机器软件版本号、波特率等参数。

Click "Other Interfaces" to enter the machine software version interface. This page displays the machine software version number, baud rate and other parameters.

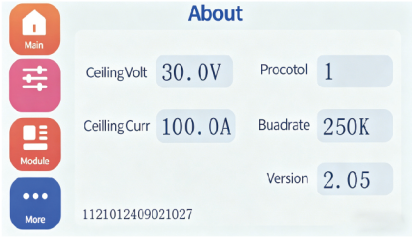
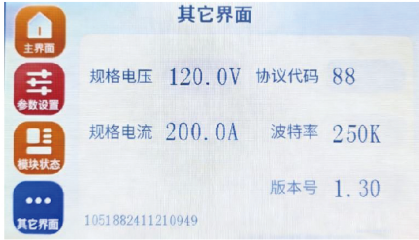

## 五、使用方法

### 5. Operation Method

#### 1. 充电操作步骤

##### 1. Charging Operation Steps

- 1) 车辆停稳，关闭电源，打开充电舱门及保护盖；
- 2) 合上充电设备电源输入总闸，充电设备开启并自检；
- 3) 取下充电枪，顺直枪线，与车辆正确连接，自动充电开始；
- 4) 自动充电完成后，拔出充电枪，收卷枪线，放置充电枪搁置处；
- 5) 盖上车辆充电保护盖及舱门，关闭充电机电源，充电结束；
- 6) 0°C以下低温环境，车辆使用完毕后请立即充电，避免低温造成不能充电；

Park the vehicle stably, turn off the power, and open the charging compartment door and protective cover; Close the main input power switch of the charging equipment, and the charging equipment turns on and performs self-inspection; Remove the charging gun, straighten the gun cable, connect it correctly to the vehicle, and automatic charging starts; After the automatic charging is completed, pull out the charging gun, retract the gun cable, and place the charging gun in the holder; Cover the vehicle charging protective cover and compartment door, turn off the charger power, and the charging ends; In a low-temperature environment below 0°C, charge the vehicle immediately after use to avoid failure to charge due to low temperature.

#### 2. 充电注意事项

##### 2. Charging Precautions

- 1) 充电前，确保车辆电源关闭；
- 2) 保持充电接口表面清洁，接口内无颗粒、粉尘等杂物；
- 3) 当充电接口非金属部分温度高达 85 度时，请立即停止充电；
- 4) 紧急情况下，请立即断开充电机输入电源；
- 5) 请确保按下暂停按钮且充电枪解锁后再拔充电枪，禁止充电过程中直接拔掉充电枪；

Park the vehicle stably, turn off the power, and open the charging compartment door and protective cover; Close the main input power switch of the charging equipment, and the charging equipment turns on and performs self-inspection; Remove the charging gun, straighten the gun cable, connect it correctly to the vehicle, and automatic charging starts; After the automatic charging is completed, pull out the charging gun, retract the gun cable, and place the charging gun in the holder; Cover the vehicle charging protective cover and compartment door, turn off the charger power, and the charging ends; In a low-temperature environment below 0°C, charge the vehicle immediately after use to avoid failure to charge due to low temperature.

#### 3. 充电枪电磁锁

##### 3. Charging Gun Electromagnetic Lock

- 1) 当充电机正常输出时，充电枪上电磁锁自动锁紧，此时无法拔出充电枪；
- 2) 当充电完成、操作暂停按钮或故障时，充电枪上电磁锁自动解锁，此时可以拔出充电枪；

When the charger outputs normally, the electromagnetic lock on the charging gun is automatically locked, and the charging gun cannot be pulled out at this time; When charging is completed, the pause button is operated or a fault occurs, the electromagnetic lock on the charging gun is automatically unlocked, and the charging gun can be pulled out at this time.

## ⚠ 注意 Note:

- 1) 仅当电磁锁解锁后,才能正常拔出充电枪;
- 2) 当电磁锁故障无法解锁后,可以直接关闭充电机电源,再次检查充电枪是否可以拔出,如果依然无法拔出,可以使用应急解锁方法;

The charging gun can only be pulled out normally when the electromagnetic lock is unlocked;  
If the electromagnetic lock fails to unlock, the charger power can be turned off directly, and check again whether the charging gun can be pulled out. If it still cannot be pulled out, the emergency unlocking method can be used.

## 4. 充电枪电磁锁应急解锁方法

### 4. Emergency Unlocking Method for Charging Gun Electromagnetic Lock

- 1) 将螺丝刀缓慢插入预留应急解锁功能孔;
- 2) 将螺丝刀插入孔内往内部方向轻轻按压,使电磁锁杆退回;

Insert a screwdriver into the reserved emergency unlocking hole slowly;  
Insert the screwdriver into the hole and press gently inward to retract the electromagnetic lock pin.



## ⚠ 警告 Warning

在正常情况下,严禁使用应急解锁方法。

The emergency unlocking method is strictly prohibited under normal circumstances.

## 六、保护和故障列表

### 6. Protection and Fault List

#### 1. 输入保护

##### 1. Input Protection

过压; 欠压; 缺相保护。

Overvoltage; Undervoltage; Phase loss protection.

#### 2. 输出保护

##### 2. Output Protection

短路; 过压; 欠压。

Short circuit; Overvoltage; Undervoltage.

#### 3. 其他

##### 3. Other Protections

充电枪过热保护: 当充电枪温度  $> 75^{\circ}\text{C}$  则充电机触发限流输出, 温度每升高  $1^{\circ}\text{C}$ , 电流下降 5%, 当温度达到  $85^{\circ}\text{C}$  触发停机, 待温度下降  $75^{\circ}\text{C}$  后, 自动进入充电。当第四次触发  $85^{\circ}\text{C}$  停机则不会再恢复, 此时触摸屏上故障信息显示为“充电枪过温”。只有启充电机, 故障才能解除。

Charging gun overheating protection: The charger triggers current-limiting output when the charging gun temperature  $> 75^{\circ}\text{C}$ , the current drops by 5% for every  $1^{\circ}\text{C}$  increase in temperature, and triggers shutdown when the temperature reaches  $85^{\circ}\text{C}$ , and automatically resumes charging when the temperature drops to  $75^{\circ}\text{C}$ . If the  $85^{\circ}\text{C}$  shutdown is triggered for the fourth time, it will not resume, and the fault information on the touch screen will display "Charging Gun Overtemperature". The fault can only be eliminated by restarting the charger.

#### 4. 保护动作

##### 4. Protection Actions

1) 一般性保护: 输入欠压、输入缺相、充电机过热、充电机输出欠压、电池低温、电池过温、电池故障保护等, 故障消除可自动恢复充电。

2) 不可自恢复保护: 输出短路、充电枪温度异常等。

General protection: Input undervoltage, input phase loss, charger overheating, charger output undervoltage, battery low temperature, battery overtemperature, battery fault protection, etc. Charging can be automatically resumed after the fault is eliminated.

Non-self-recoverable protection: Output short circuit, abnormal charging gun temperature, etc.

## 5.故障列表

### 5.Fault List

故障类别 Fault Category	序号 No.	故障信息 Fault Information	备注 Remarks
电网故障 Power Grid Fault	1	输入缺相 Input Phase Loss	请检查交流电网 Check the AC power grid
	2	电网异常 Abnormal Power Grid	
充电机故障 Charger Fault	1	充电机模块通讯异常 Abnormal Communication of Charger Module	请检查充电机 Check the charger
	2	BMS通讯异常 Abnormal BMS Communication	
	3	风扇故障 Fan Fault	
	4	电流过高 Excessively High Current	
	5	温度过高 Excessively High Temperature	
	6	电压过高 Excessively High Voltage	
	7	充电枪过温 Charging Gun Overtemperature	
电池故障 Battery Fault	1	电池总压过充保护 Battery Total Voltage Overcharge Protection	请检查电池 Check the battery
	2	电池过温过充保护 Battery Overtemperature Overcharge Protection	
	3	电池互锁保护 Battery Interlock Protection	
	4	电池低温保护 Battery Low Temperature Protection	
	5	电池单体电压过低 Excessively Low Single Battery Voltage	
	6	充电电流过大 Excessively High Charging Current	
	7	BMS故障保护 BMS Fault Protection	
	8	电池充电座过温保护 Battery Charging Base Overtemperature Protection	
	9	电池CC2异常 Abnormal Battery CC2	
	10	电池单体压差过大 Excessively Large Voltage Difference of Single Batteries	
	11	电池单体温差过大 Excessively Large Temperature Difference of Single Batteries	
其他故障 Other Fault	1	请接电池 Please Connect Battery	请检查充电连接 Check the charging connection
	2	无电池电压 No Battery Voltage	请检查车辆是否已关闭,处于待充电态 Check if the vehicle is turned off and in the to-be-charged state

## 七、维护与保养

### 7. Maintenance and Upkeep

为使充电机能长期可靠连续运行,防患于未然,应进行日常检查或定期检查,注意以下的项目:

To ensure the long-term, reliable and continuous operation of the charger and prevent problems before they occur, daily or regular inspections should be carried out, paying attention to the following items:

#### 1. 日常检查:

##### 1. Daily Inspection

通电运行时,目检充电机的运行确认没有异常情况,通常检查以下各点:

- 1) 运行性能符合标准工艺规范;
- 2) 周围环境符合标准规范(见使用环境表);
- 3) 充电机枪内有无杂物、水渍、灰尘,如有请用干燥的布擦拭干净;
- 4) 没有异常的噪声、振动和异常气味;
- 5) 风机是否正常运转;
- 6) 没有过热或变色等异常情况;
- 7) 输入电压是否在正常的工作范围;
- 8) 各连接线接头是否紧固。
- 9) 输入输出电缆线绝缘是否破损、铜线外露等现象,一旦发现立即停止使用更换好的电缆线束。

During power-on operation, visually inspect the operation of the charger to confirm no abnormal conditions, usually checking the following points:

The operating performance complies with the standard process specifications;

The surrounding environment complies with the standard specifications (see the operating environment table);

Check for debris, water stains and dust inside the charger gun, and wipe it clean with a dry cloth if any;

No abnormal noise, vibration and peculiar smell;

Whether the fan is operating normally;

No abnormal conditions such as overheating or discoloration;

Whether the input voltage is within the normal working range;

Whether all wiring connectors are tight;

Check if the insulation of the input and output cables is damaged or the copper wire is exposed; stop using immediately and replace with a good cable harness if found.

#### 2. 定期检查保养:

##### 2. Regular Inspection and Maintenance

- 1) 充电机每隔 30 天(根据环境状况调整)清理一次风机出风口的沉积物,以便出风窗口畅通无阻,保持风流量,以利整机散热。
- 2) 定期检查充电机内的输入、输出端子及是否插接完好,只有插接完好才能确保充电正常。

Clean the deposits at the fan air outlet of the charger every 30 days (adjust according to environmental conditions) to keep the air outlet unobstructed, maintain air flow and facilitate heat dissipation of the whole machine.

Regularly check whether the input and output terminals inside the charger are properly plugged; proper plugging is essential to ensure normal charging.

---

## 八、包装、运输及储存

### 8.Packaging, Transportation and Storage

#### 1. 包装

##### 1. Packaging

本产品采用木箱或纸箱包装, 包装箱内包含安装使用说明书, 每个充电机有出厂合格证。

This product is packaged in wooden cases or cartons, which contain the installation and operation manual, and each charger is attached with a factory qualification certificate.

#### 2. 运输

##### 2.Transportation

本产品运输应在包装完好情况下进行, 搬运过程中不得剧烈震动和碰撞, 防止受潮和雨淋。

This product shall be transported in intact packaging, without severe vibration and collision during handling, and protected from moisture and rain.

#### 3. 储存

##### 3.Storage

本产品应储存在-40~+75°C、相对湿度不大于 95%、无腐蚀性气体、空气流通的室内, 储存期为 6 个月。

This product shall be stored in an indoor environment with a temperature of -40~+75°C, relative humidity not more than 95%, no corrosive gas and good air circulation, with a storage period of 6 months.

# 附录A: 充电机原理图

## Appendix A: Charger Wiring Schematic

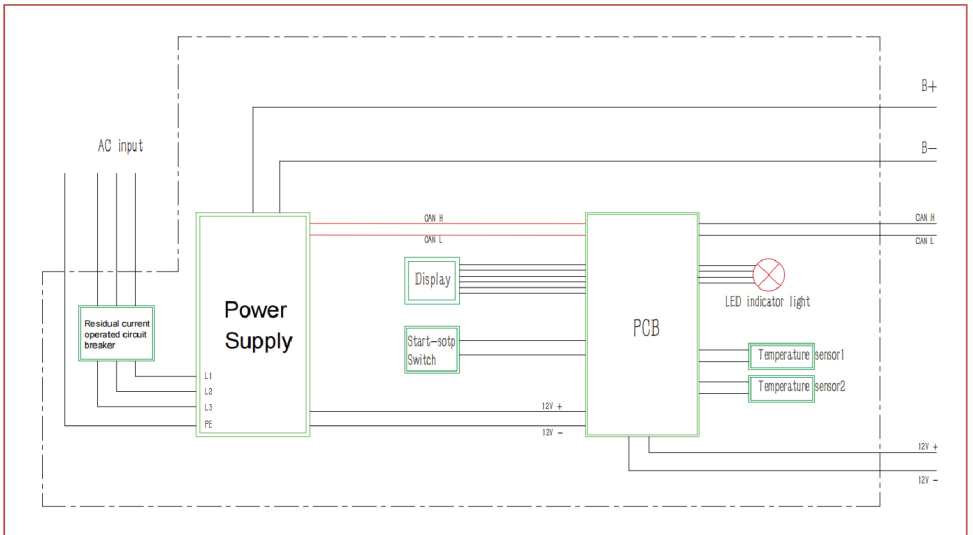
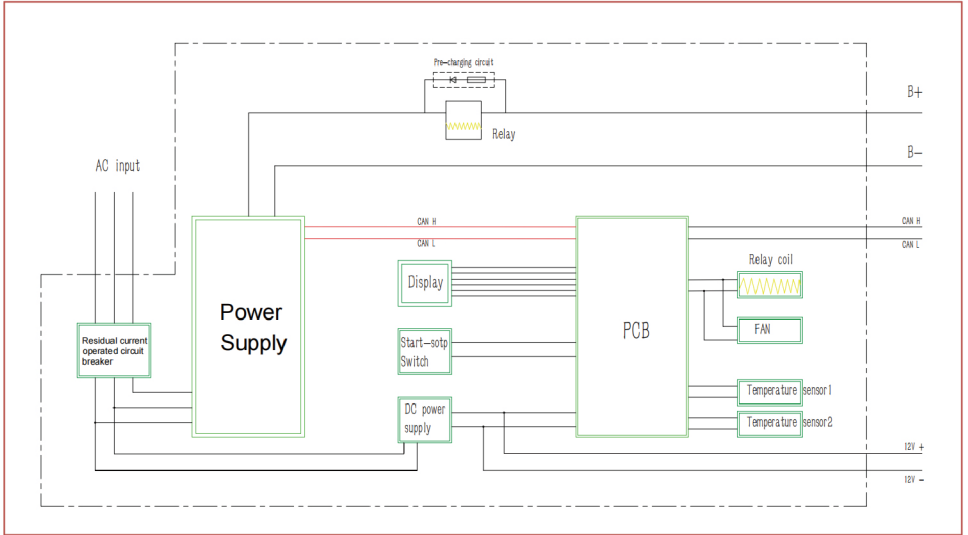

## 附录B: 常见故障及处理

### Appendix C: Common Faults and Troubleshooting

显示故障 Displayed Fault	故障说明 Fault Description	可能故障和排除方法 Possible Faults & Troubleshooting
请接电池 Please connect the battery	充电器未检测到电池包电压, 和交互报文判定为后端无电池  The charger does not detect the battery pack voltage and judges that there is no battery at the rear end according to the interactive message.	1. 电池包是否唤醒 2. 连接器连接牢靠 3. 正负极连接线是否正确 4. 充电器检测电路故障 万用表检测连接器部位电压, 有电压则充电器检测电路故障, 无电压则电池未唤醒 1. Check if the battery pack is awakened. 2. Check if the connector is securely connected. 3. Check if the positive and negative cables are connected incorrectly. 4. The charger detection circuit is faulty. Use a multimeter to measure the voltage at the connector. If voltage is present, the charger detection circuit is faulty. If no voltage is detected, the battery is not awakened.
BMS通讯异常 BMS communication abnormal	已检测到电池电压未接收到BMS报文 Battery voltage detected, but BMS message not received.	1. 连接器信号线束故障 2. BMS未发送报文 3. 充电器接收报文故障 使用屏幕报文界面读取报文, 有报文交互则充电器故障, 无报文交互则BMS未发送可通过CAN盒验证 1. Signal harness fault of the connector 2. BMS does not send messages 3. Charger message reception fault Read messages via the screen message interface. If there is message interaction, the charger is faulty. If there is no message interaction, the BMS does not send messages. Verification can be done via a CAN box.
无电池电压 No battery voltage	已检测充电报文未检测到电池包电压 Charging message detected, Battery pack voltage not detected.	需要万用表测量充电器与电池连接线。 1. 实测有电压, 则充电器检测电路故障 2. 实测无电压, 则电池包线路故障。 Use a multimeter to measure the connection cable between the charger and the battery. If voltage is detected, the charger detection circuit is faulty. If no voltage is detected, the battery pack circuit is faulty.
停止充电 Charging stopped	充电器暂停充电 Charger paused charging	1. 人工按键停止 2. 报文交互停止, 此时需解析报文, 见报文界面 Stopped by manual button. Stopped by message interaction. In this case, parse the messages on the message interface.
模块通讯异常 Module communication abnormal	功率模块和控制器通讯超时 Power module communication timeout with controller	充电器内部故障 一般判定为连接线束故障 Internal fault of the charger Generally judged as wiring harness fault
充电枪过温 Charging gun over-temperature	充电枪头温度超85° Charging gun temperature exceeds 85°C	1. 温度传感器故障 2. 实际温度高, 则需核验连接器或枪头的匹配。 1. Temperature sensor fault. 2. If the actual temperature is high, check the matching of the connector or gun head.
输入缺相 Input phase loss	三相交流电网缺相 Three-phase AC grid phase loss	1. 关机时会出现, 正常现象, 2. 上电后出现, 需要观察模块指示灯, 3. 红色异常。 可用万用表交流档复核。 It may appear during power-off, which is normal. If it appears after power-on, observe the module indicator light. Red light indicates an abnormality.

**注: 充电器出现故障现象不在以上列表, 或经以上排查问题没有解决, 请与厂家联系!**

Note: If the charger fault is not listed above or the problem remains unsolved after troubleshooting, please contact the manufacturer!

# 附录C:故障处理流程图

## Appendix D: Fault Handling Flow Chart

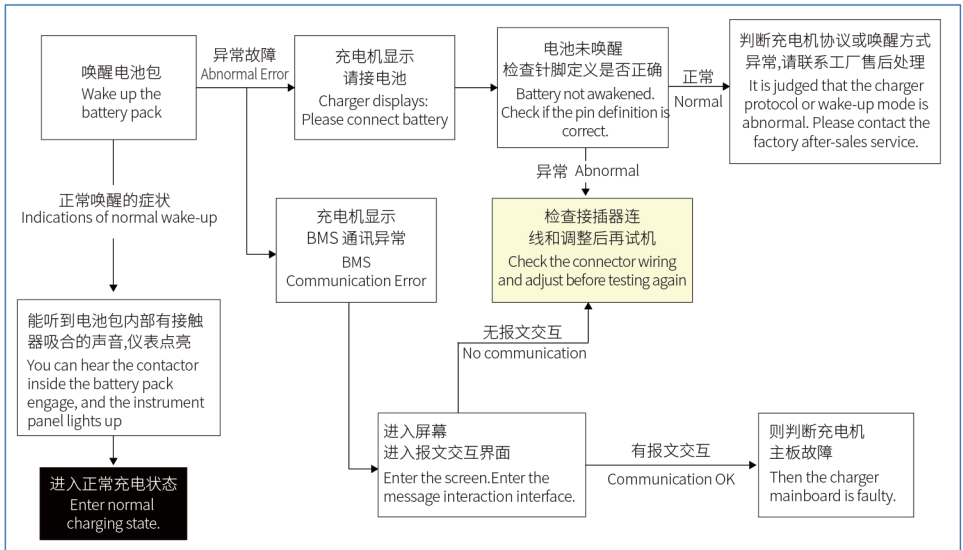
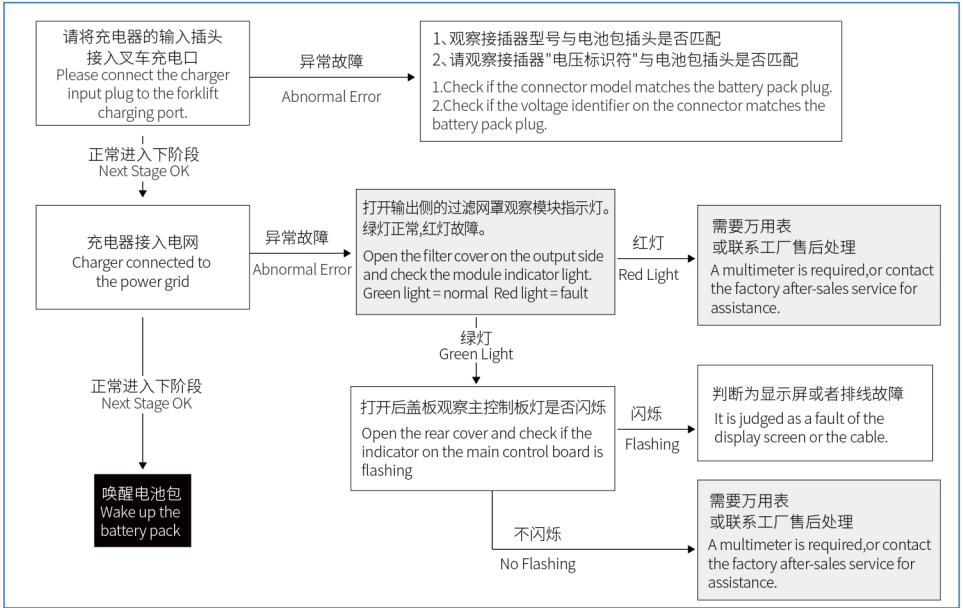

注: 以上流程为示例参考流程, 不要求完全一致。

Note: The above process is for reference only and does not need to be fully followed.

## 附录D: 常用检修工具

### Appendix E: Common Maintenance Tools

- 1、数字万用表(需要用蜂鸣档、电阻档、直流电压档、交流电压档)。图片1
- 2、有条件可以适配CAN盒和笔记本电脑。图片2

Digital multimeter (with buzzer, resistance, DC voltage and AC voltage functions). Image 1  
CAN box and laptop are recommended if available. Image 2



图片 1(Image 2)



图片2(Image 2)

### REMA口定义示意图

REMA Port Definition Diagram

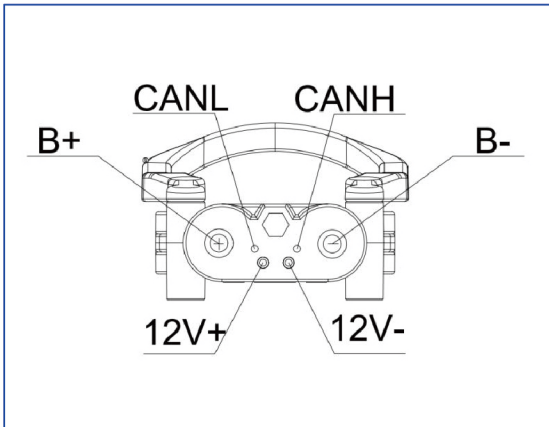

注: 该示例图是为说明针脚位置关系, 具体实物请参见订单详情。

Note: The sample diagram is for illustrating the pin position relationship. For the actual product, please refer to the order details.